

STORMWATER MANAGEMENT(SWM) FOR SMALL PROJECTS

DOVER TOWNSHIP "SMALL PROJECT GUIDE"

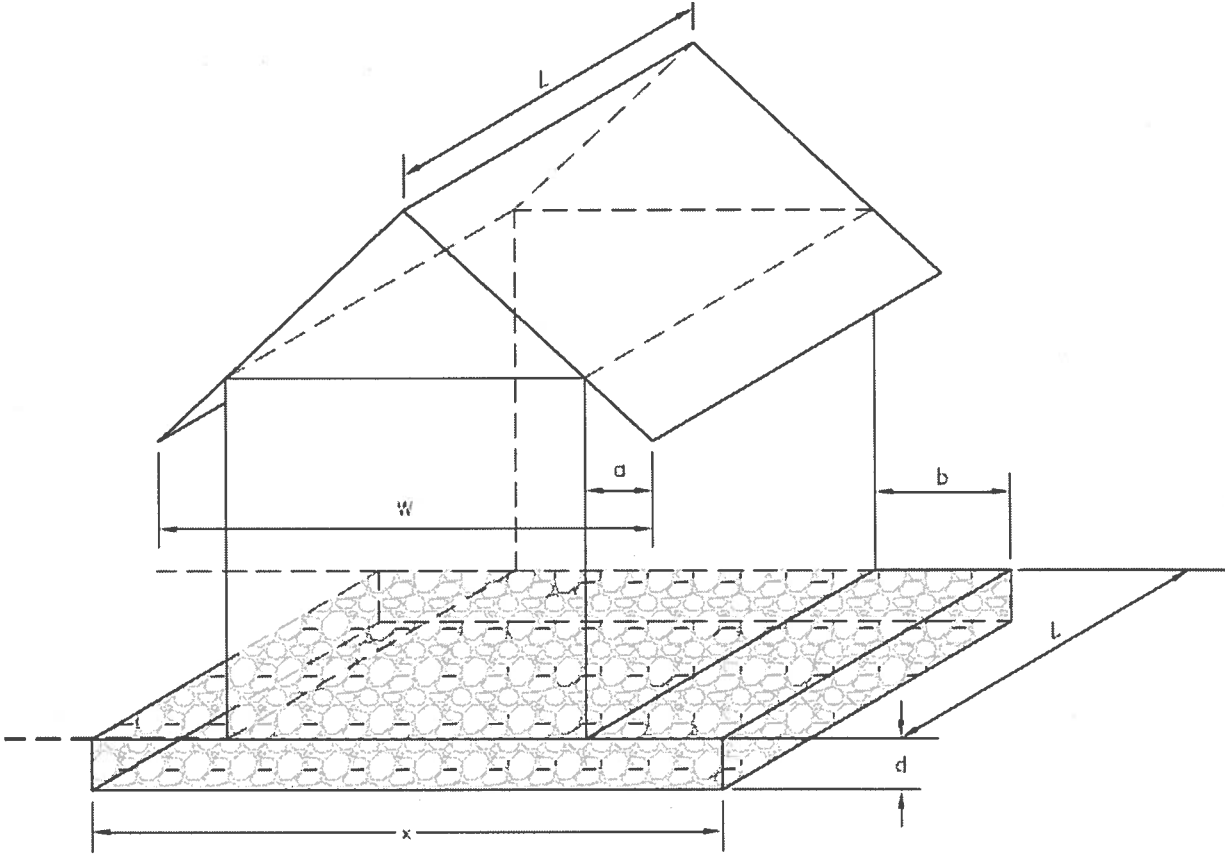

January 2015

This guide is intended to assist the property owner in completing a Stormwater Management (SWM) Permit Application for single lot “small” projects **not requiring a SWM Site Plan⁽¹⁾** such as installing a shed, building a small extension to a house, installing or expanding a driveway, or enclosing a deck or patio.

A SWM Site Plan will be required for single lot projects:

- involving 1,000 sq. ft or more of new impervious surface
- involving less than 1,000 square feet of new impervious surface when SWM cannot be achieved by utilizing the BMPs⁽²⁾ found in Dover Township’s “Small Project Guide” (this document).
- if the project site is considered unsuitable for the BMPs found in the Dover Township “Small Project Guide”.

There are basically 3 Stormwater Management options available to you in the “Small Project Guide”.

- 1) Disconnected Impervious Area (DIA)
- 2) Stone Infiltration Structure (which includes beds and trenches)
- 3) Rain Garden

The “Small Project Guide” provides examples of stone infiltration structures and a rain garden. If you intend to use one of these BMPs include a copy of the example BMP with your application and sketch plan. Township Staff is available to assist you with sizing an infiltration structure or rain garden.

Disconnected Impervious Area (DIA)

If you choose to utilize an DIA as your Stormwater Management option, you must demonstrate on the Sketch Plan that the following DIA criteria can be met:

For Structures:

- Is there less than 500ft² (of roof top) draining to an individual downspout?
- Is there a 75' pervious flow path available on the same property?
- Is the flow path < 5% slope?

For Pavement/Patios/At-grade Impervious Areas:

- Is the WIDTH of the impervious area less than 75'?
- Is the pervious flow path greater than the length of impervious surface?
- Is the flow path < 5% slope?

If you have any questions or need additional information, you may call (292-3634) or email cfarley@dovertownship.org.

Chuck Farley
Director of Public Works

SWM Site Plan⁽¹⁾ Stormwater Management Site Plan – the requirements for a Stormwater Management Site Plan are listed in Dover Township Stormwater Management Ordinance Section 19-401 Plan Requirements. The SWM Site Plan must be prepared by a qualified professional person and must be reviewed by the Township’s Engineer.

BMPs⁽²⁾ Best Management Practices – activities, facilities, designs, measures or procedures used to manage stormwater impacts from regulated activities, to meet state water quality requirements, to promote groundwater recharged, and to otherwise meet conditions of the Dover Township SWM Ordinance

DIA⁽³⁾ Disconnected Impervious Area – an impervious or impermeable surface that is disconnected from any stormwater drainage or conveyance system and is redirected or directed to a pervious area, which allows for infiltration, filtration, and increased time of concentration

NOTE:
THIS PLAN CAN
BE HAND DRAWN.

Main Street

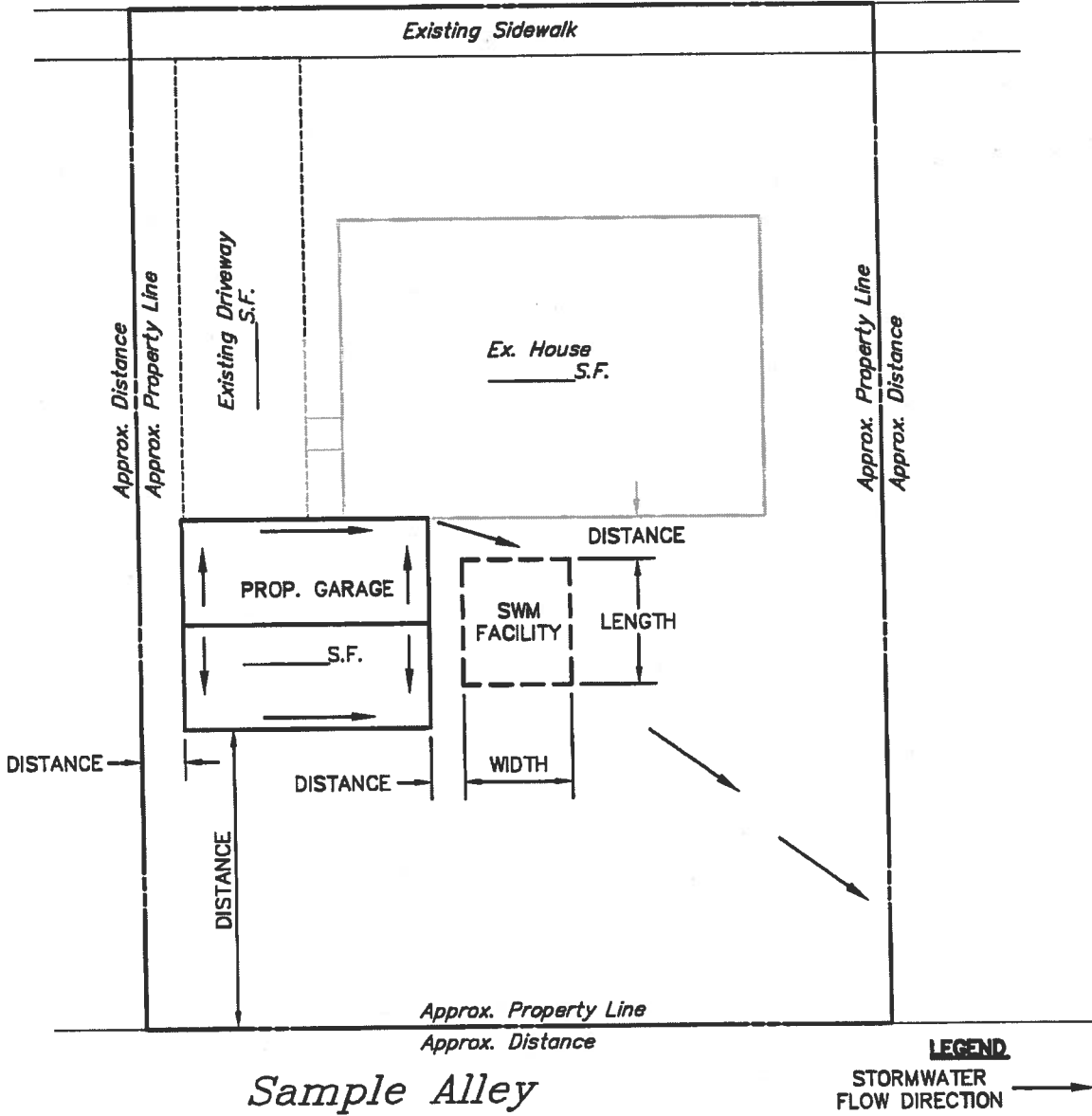

ATTACHMENT A1
SAMPLE SKETCH/ SITE PLAN

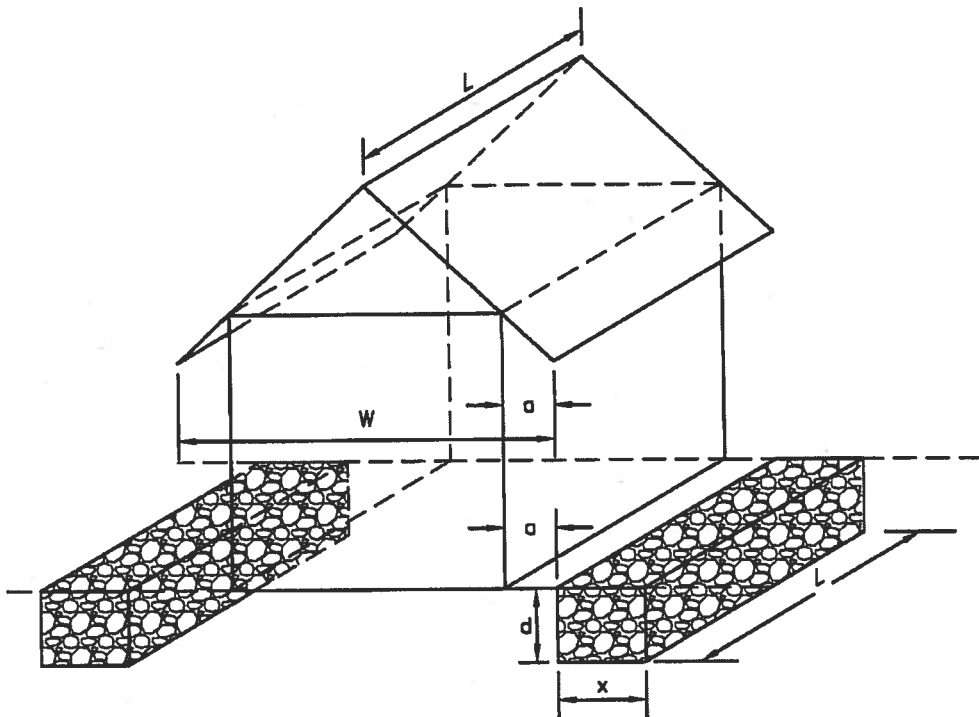

KEY

- L = LENGTH OF STRUCTURE = LENGTH OF SEEPAGE TRENCH (FT.)
- W = WIDTH STRUCTURE (FT)
- a = EAVE OVERHANG (FT) = TRENCH DISTANCE FROM STRUCTURE (FT)
- x = WIDTH OF SEEPAGE TRENCH (FT)
- d = DEPTH OF SEEPAGE TRENCH (FT)

REQUIRED VOLUME OF EACH TRENCH $\Rightarrow [L*W*(2/12)]/2 = (L*x*d*0.4)/2 \Rightarrow x=0.14*W$ (ASSUMING $d=1.5'$)

NOTES

1. TRENCH MUST BE PROVIDED ON EACH SIDE OF STRUCTURE.
2. SIDE OF TRENCH TO BE WRAPPED IN CLASS 1 GEOTEXTILE.
3. TRENCH TO BE FILLED WITH CLEAN STONE (3/4" MIN. SIZE).
4. TRENCH TO BE CONSTRUCTED AT 0% SLOPE ON UNDISTURBED SOIL.
5. TRENCH TO BE CHECKED REGULARLY TO MAINTAIN PROPER OPERATION.

ATTACHMENT B1
STRUCTURES WITHOUT GUTTERS A

Note:
Bed Should Be Installed
6" into the Ground

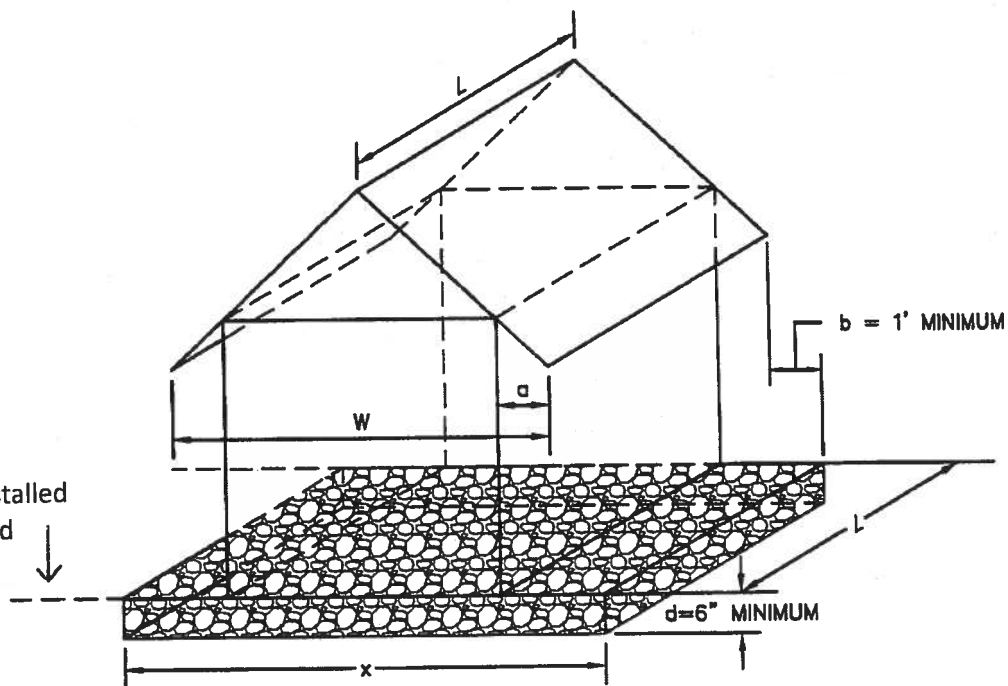

KEY

- L = LENGTH OF STRUCTURE = LENGTH OF SEEPAGE BED (FT.)
- W = WIDTH OF STRUCTURE (FT)
- a = EAVE OVERHANG (FT)
- b = DISTANCE FROM EAVE OVERHANG TO EDGE OF SEEPAGE BED (FT) = 1' MINIMUM
- d = DEPTH OF SEEPAGE BED = 6" MINIMUM
- x = WIDTH OF SEEPAGE BED (FT)
- x = W + 2 FT

NOTES

- 1.) SIDE OF BED TO BE WRAPPED IN CLASS 1 GEOTEXTILE.
- 2.) BED TO BE FILLED WITH CLEAN STONE (3/4" MIN. SIZE).
- 3.) BED TO BE CONSTRUCTED AT 0% SLOPE ON UNDISTURBED SOIL.
- 4.) BED TO BE CHECKED REGULARLY TO MAINTAIN PROPER OPERATION.

ATTACHMENT B2
STRUCTURES WITHOUT GUTTERS B

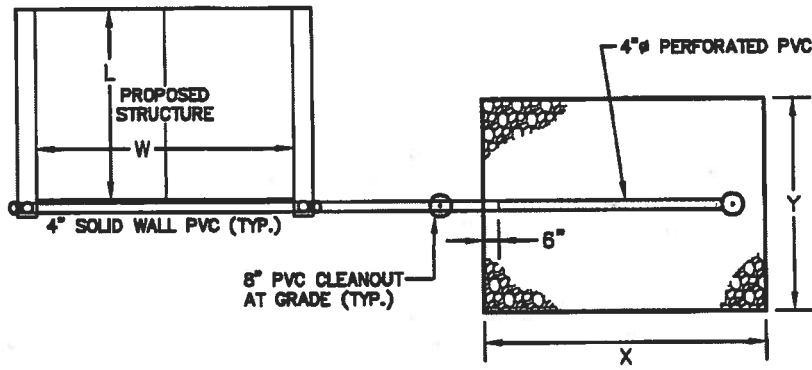

PLAN VIEW

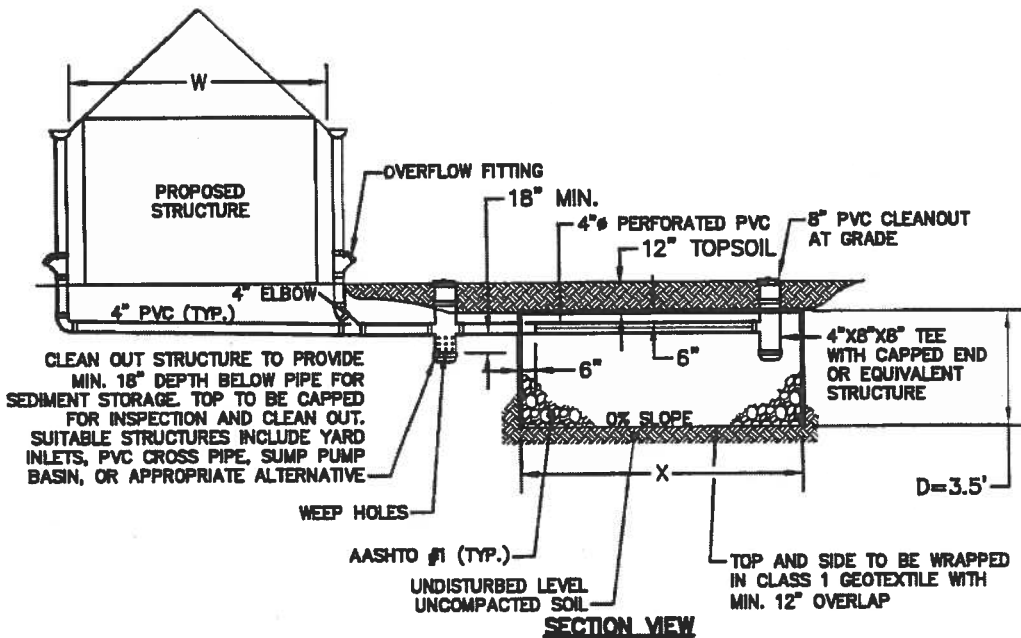

SECTION VIEW

CLEAN OUT STRUCTURE TO PROVIDE MIN. 18" DEPTH BELOW PIPE FOR SEDIMENT STORAGE. TOP TO BE CAPPED FOR INSPECTION AND CLEAN OUT. SUITABLE STRUCTURES INCLUDE YARD INLETS, PVC CROSS PIPE, SUMP PUMP BASIN, OR APPROPRIATE ALTERNATIVE

NOTES

1. BOTTOM OF BED ELEVATION TO BE 4.5' BELOW SURFACE TO ACCOUNT FOR 1' OF TOPSOIL OVER INFILTRATION BED. IN THE EVENT THE REQUIRED BED DEPTH CANNOT BE ACHIEVED DUE TO SITE CONDITIONS, REDESIGN OF THIS STRUCTURE WITH TOWNSHIP ASSISTANCE WILL BE REQUIRED.
2. PIPE TO BE APPROPRIATELY SIZED TO CARRY ROOF WATER. PVC PIPE SHALL HAVE A MIN. DIAMETER OF 4".
3. PIPING AND CLEANOUTS TO BE CENTERED WITHIN INFILTRATION BED.
4. BED TO BE CHECKED REGULARLY TO MAINTAIN PROPER OPERATION.

KEY

- L = LENGTH OF STRUCTURE ROOF (FT)
- W = WIDTH OF ENTIRE ROOF (FT)
- X = WIDTH OF INFILTRATION BED (FT)
- Y = LENGTH OF INFILTRATION BED (FT)

REQUIRED VOLUME OF BED $L*W^2/12$
 $L*W^2/12 = X*Y*D*0.4$
 ASSUME: $X=W$; $D=3.5'$
 $Y=0.12L$

ATTACHMENT B3
STRUCTURES WITH GUTTERS

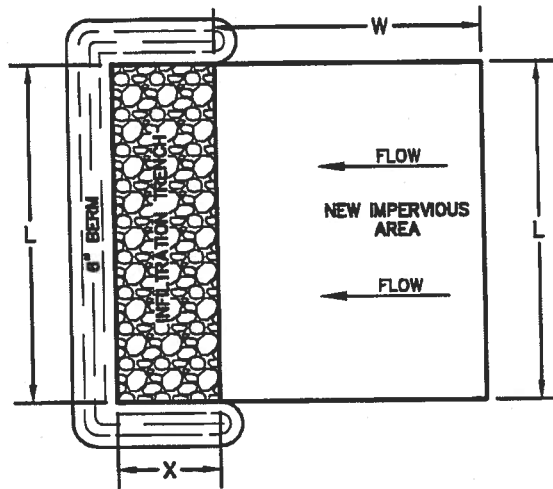

PLAN VIEW

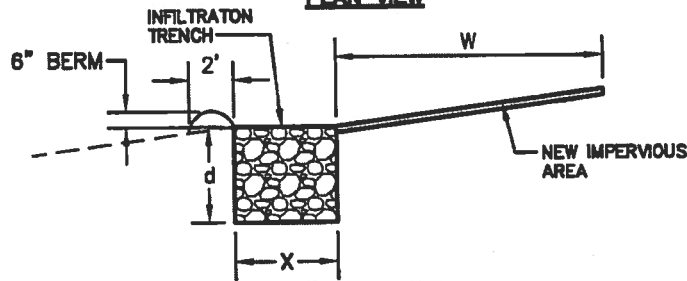

SECTION VIEW

KEY

- L = LENGTH OF NEW IMPERVIOUS SURFACE (FT) = LENGTH OF INFILTRATION TRENCH
- W = WIDTH OF NEW IMPERVIOUS SURFACE TRENCH (NOT TO EXCEED 75')
- X = WIDTH OF SEEPAGE TRENCH (FT)
- d = DEPTH OF SEEPAGE TRENCH (FT) = 1.5'

REQUIRED VOLUME OF TRENCH => $W*L*2/12 = X*L*d*0.4$ => $X=0.28L$ (d=1.5')

NOTES

- 1.) SIDE OF TRENCH TO BE WRAPPED IN PENNDOT CLASS 1 GEOTEXTILE.
- 2.) TRENCH TO BE FILLED WITH CLEAN STONE (3/4" MIN. SIZE).
- 3.) TRENCH TO BE CONSTRUCTED AT 0% SLOPE ON UNDISTURBED SOIL.
- 4.) TRENCH TO BE CHECKED REGULARLY TO MAINTAIN PROPER OPERATION.
- 5.) THE TOWNSHIP MAY WAIVE THE REQUIRED INSTALLATION OF A 6" BERM AT THEIR DISCRETION.

ATTACHMENT B4
AT GRADE IMPERVIOUS

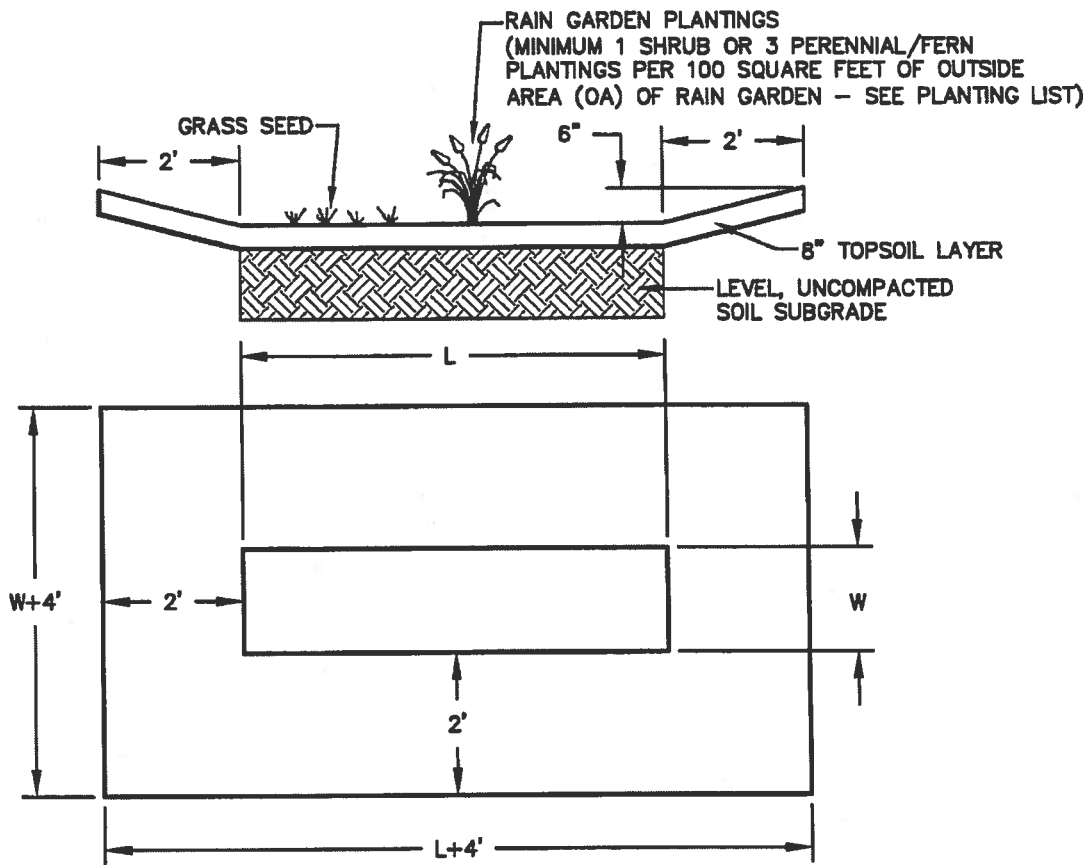

1. CALCULATE REQUIRED RAIN GARDEN VOLUME (RV)
(RV) = SQUARE FEET OF NEW IMPERVIOUS AREA X 0.17'

RV = _____ ft³

2. CALCULATE INSIDE AREA OF RAIN GARDEN (IA)
(IA) = LENGTH (L) X WIDTH (W)

IA = _____ ft²

3. CALCULATE OUTSIDE AREA OF RAIN GARDEN (OA)
(OA) = [LENGTH (L) + 4'] X [WIDTH (W) + 4']

OA = _____ ft²

4. CALCULATE AVERAGE AREA OF RAIN GARDEN (AA)
(AA) = INSIDE AREA (IA)/2 + OUTSIDE AREA (OA)/2

AA = _____ ft²

5. CALCULATE STORAGE VOLUME (SV)
(SV) = AVERAGE AREA (AA) X 0.5'

SV = _____ ft³

6. CHECK FOR ADEQUATE STORAGE
STORAGE VOLUME (SV) MUST BE GREATER THAN REQUIRED VOLUME (RV)
SV = _____ ft³ > RV = _____ ft³

7. ADJUST RAIN GARDEN SIZE
IF STORAGE VOLUME (SV) IS NOT GREATER THAN THE REQUIRED VOLUME (RV), INCREASE THE SIZE OF THE LENGTH (L) AND/OR WIDTH (W) AND REPEAT STEPS 2-6

ATTACHMENT B5
RAIN GARDEN

Rain Garden Native Planting List

Perennials and Ferns:

Blue false indigo (*Baptisia australis*)
Blue flag iris (*Iris versicolor*)
Blue star (*Amsonia tabernaemontana*)
Blue vervain (*Verbena hastata*)
Boltonia (*Boltonia asteroides*)
Boneset (*Eupatorium perfoliatum*)
Bottlebrush grass (*Hystrix patula*)
Broomsedge (*Andropogon virginicus*)
Cardinal flower (*Lobelia cardinalis*)
Cinnamon fern (*Osmunda cinnamomea*)
Culvers root (*Veronicastrum virginicum*)
Golden ragwort (*Senecio aureus*)
Goldenrod (*Solidago patula*, *S. rugosa*)
Great blue lobelia (*Lobelia siphilitica*)
Green bullrush (*Scirpus atrovirens*)
Horsetail (*Equisetum* species)
Marsh marigold (*Caltha palustris*)
Mistflower (*Eupatorium colestinum*)
Monkey flower (*Mimulus ringens*)
New England aster (*Aster novae-anglia*)
New York aster (*Aster novi-belgii*)
Obedient plant (*Physotegia virginiana*)
Royal fern (*Osmunda regalis*)
Seedbox (*Ludwigia alternifolia*)
Sensitive fern (*Onoclea sensibilis*)
Sneezeweed (*Helenium autumnale*)
Soft rush (*Juncus effusus*)
Swamp milkweed (*Asclepias incarnata*)
Swamp rose mallow (*Hibiscus moscheutos*)
Swamp sunflower (*Helianthus angustifolius*)
Switchgrass (*Panicum virgatum*)
Threadleaf coreopsis (*Coreopsis verticillata*)
Tussock sedge (*Carex stricta*)
White turtlehead (*Chelone glabra*)
Woolgrass (*Scirpus cyperinus*)

Shrubs:

American beautyberry (*Callicarpa americana*)
Arrowwood (*Viburnum dentatum*)
Black chokeberry (*Aronia melanocarpa*)
Broad-leaved meadowsweet (*Spiraea latifolia*)
Buttonbush (*Cephalanthus occidentalis*)
Elderberry (*Sambucus canadensis*)
Inkberry (*Ilex glabra*)
Narrow-leaved meadowsweet (*Spiraea alba*)
Ninebark (*Physocarpus opulifolius*)
Possumhaw (*Viburnum nudum*)
Red-osier dogwood (*Cornus sericea*)
St. Johnswort (*Hypericum densiflorum*)
Silky dogwood (*Cornus amomum*)
Smooth alder (*Alnus serrulata*)
Spicebush (*Lindera benzoin*)
Swamp azalea (*Rhododendron viscosum*)
Swamp rose (*Rosa palustris*)
Sweet pepperbush (*Clethra alnifolia*)
Wild raisin (*Viburnum cassinoides*)
Winterberry (*Ilex verticillata*)
Virginia sweetspire (*Itea virginica*)